

PRODUCTS INSTALLATION INSTRUCTIONS

Model: 798141RB/798199RB
Description: 1.7m Free Standing Bathtub

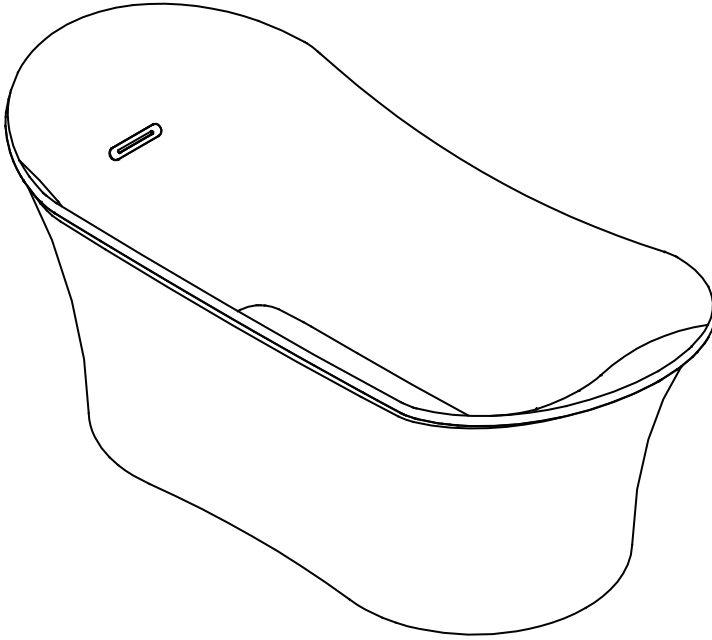

PRODUCT DESCRIPTION

1. Dimensions: 1700X760X680mm
2. Material: Acrylic
3. Full water volume is: 170L (up to overflow outlet)

A INSTALLATION DIMENSION

Unit:mm

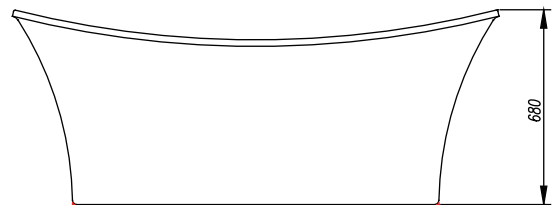
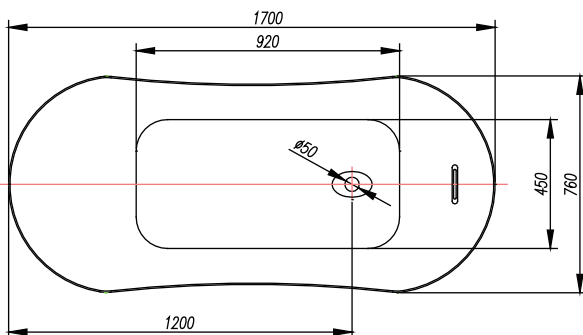

B HELPFUL TOOLS

Adjustable Wrench

Marking Gauge and Pencil

Tape Measure

Neutral Mildew Resistant
Silicone Sealant

Level

Safety Glasses

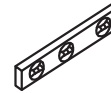

C POINTS FOR ATTENTION BEFORE INSTALLATION

1. In order to avoid quality dispute, please kindly check product before installation. Or We should not be liable for any quality issue raised after installation.
2. Please read the instruction carefully before beginning to install.
3. Please follow steps in the instruction to install this product or may result in costly mistake. We shall not be responsible for any loss from that mistake.
4. Professional help is required for installation of this product.

Inspection

- (1) Before starting installation, check and ensure bathtub, are free of leaks that may occur during delivery.
- (2) Check and ensure bathtub surface is free of hit and damage.

Attention points at Installation

- (1) To facilitate maintenance and clean, we recommend to install bathtub on finished floor with ceramic tile or terrace with ground tile.
- (2) To facilitate install and maintenance bathtub's key parts like drainage system, DON'T wall up bathtub with cement or tiles.
- (3) DON'T remove bathtub protecting film during installation.
- (4) DON'T take bathtub out of package for installation until wall and floor preparation finished.
- (5) NO bulbs and open fires are allowed to place in bathtub during installation.
- (6) NO stuff like sand, cement or other sundries are allowed to place in bathtub as that would likely damage bathtub surface.
- (7) NO solvent like paint or glue are allowed to contact with bathtub.

D INSTALLATION INFORMATION

1. The floor under the bottom of the bathtub must be able to support the weight of 1000 kg or above.
2. The hot water supply shall reach to 70% of the maximum volume of the bathtub or above.
3. Please carefully refer to the bathtub size and actual positions of the waste pump in the installation dimension diagram and compare them with the actual bathtub to determine the accurate installation dimensions.
4. Check the installation dimensions and bathroom dimensions and ensure there is sufficient space to install the bathtub.
5. Make sure that the floor for installing the bathtub is at a level.
6. Installation of the drainers: Install the drainers to the bathtub according to the installation instructions of the drainers. The figure below is the installation illustration recommended by our company specifically for the Drainer .

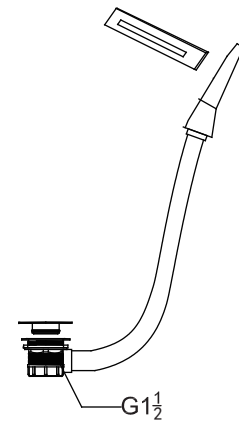
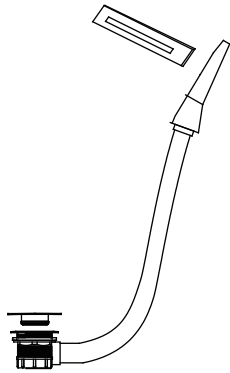

7. Installation of drain pipes: Install the drain pipes to the bathtub according to the installation instructions of the drain pipes. The figure below is the installation illustration recommended by our company for the Drain Pipe.

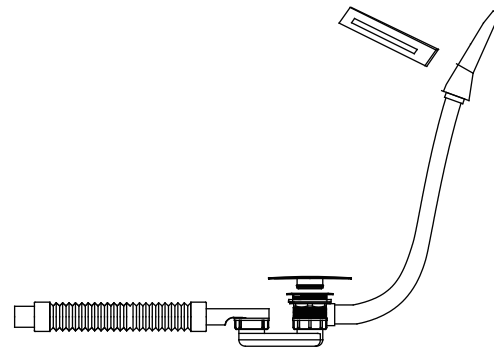

8. Switch off the water drainage, pour water into the bathtub, and then check whether there is water leakage. Make sure that the overflow adapter is leak-proof.

9. Before installation, please refer to the installation diagram. Lay water pipes on the floor, position the power outlet and hot/cold water inlet pipes. Please ask a professional plumber to complete the actual construction.

10. There are two kinds of drainage: drainage through the wall and drainage through the floor. If the drainage through the wall is used, the height of the drain pipes must be lower than that of the internal drain outlet of the bathtub. The height is generally recommended to be 50 mm. If the drainage through the floor is used, the height of the drain outlet is recommended to be 180 mm above from the drain outlet. (Drainage through the floor is recommended.)

Drainage through the floor

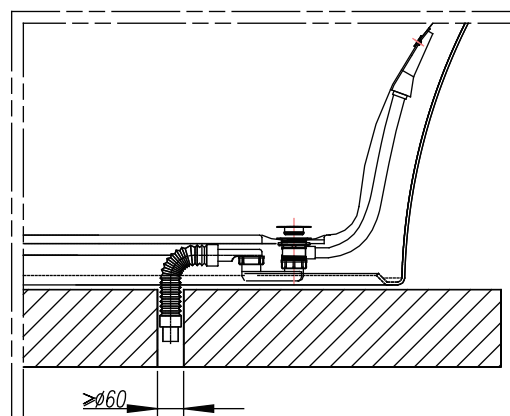

E INSTALLATION STEP

1. Before installation, please construct water pipes under ground. (Drainage outlet should be 30mm protruding from finished floor)

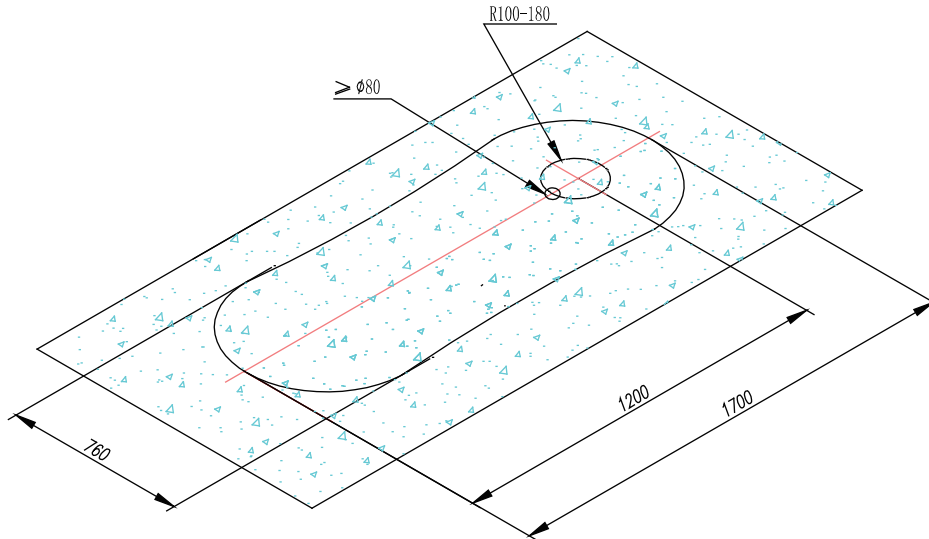

2. Adjust leveling feet to keep top rims at horizon, and ensure all feet firmly seat on floor at same time.

3. Connect supply lines and drainage lines with bathtub, using silicone sealant or other soft sealants to seal the joints between the bath rim edges and deck.

F MAINTENANCE

1. Suggest to clean bathtub immediately after drainage complete, as soap, body fat and dirt are easy to be removed at the time before bathtub dry.
2. Suggest to clean bathtub frequently if using in high hard water area, where high calcium content in water would leave yellow spot after dirt attaching on bathtub surface.
3. Please use soft cloth with neutral cleaner or soap to clean bathtub, and then wipe its surface to dry.
4. No hard stuff or abrasive stuff like cleaning powder are allowed to clean bathtub, as that would corrode, scratch and dull bathtub surface.
5. Do not allow paint, paint remover like chloroform or any strong organic solvent like acetone in contact with any bath surfaces, or bathtub surface would be softened, melted or crackle.
6. Do not place flaming cigarette on bath or it would burn bathtub surface.
7. NO bulbs and open fires are allowed to place in bathtub lest bathtub surface is damaged.

Suggestion to remove scratch:

- (1) If scratch is slight, spray metal polish or car polish on scratch at first, and then use electric polishing machine to resume glossy surface.
- (2) If scratch is deep, use 2000# abrasive paper to remove scratch at first, and then use same method as (1) to resume glossy surface.

G SPECIAL STATEMENT

The products installation instruction is written in accordance with the latest product information, following the sustainable development strategy of the Company, to improve continually the produce's specification, performance etc., subject to change without notice. (The Company reserves the right to interpret)

CERTIFICATE

Purchased from :

Date of Purchase :

Invoice Details :

Product Details :

*Please Insist on buying Products only from Authorised Dealers.

Inspector:



Manufacturing date:

WARRANTY TERMS & CONDITIONS

Model:

**INSPIRATION
ENRICHES
LIFE**

WARRANTY TERMS & CONDITIONS

Our products (hereinafter 'products' for short) are warranted by us (hereinafter 'us' for short) to be free of defects in material and workmanship.

1. The warranty clauses are applicable in the products which produced and distributed by Us.
2. The warranty clauses are merely applicable in original consumer purchaser (thereinafter 'consumer' for short) who purchase the products from us or our franchisor or the agencies designated by our franchisor.
3. The consumers should read <Product Service Manual>carefully before using.

The company provides limited warranty to the consumer as follows:

During the warranty period, We will, at its election, repair, replace or make appropriate adjustment where our inspection discloses any such defects occurring due to defective material and workmanship in normal usage. The warranty clauses are merely applicable in original consumer purchaser.

4. Warranty Period

The design and manufacture of our products obtained ISO9001 certificate of France BV Company; the performances of the products are reliable under proper use and appropriate management in light of our maintenance instructions.

- (1) Ten years limited warranty for faucet products (The service life of any disposable replacement cartridge varies with local water conditions and water consumption and thus is not warranted other than to be free of defects in material and workmanship at the time of purchase.)
- (2) One year limited warranty for porcelain and ceramics type products.
- (3) One year limited warranty for sanitary furniture products.
- (4) One year limited warranty for bathtub and electricity (sensor) products.
- (5) One year limited warranty for shower enclosures products.

We will, at its election, repair, replace or make appropriate adjustment where our inspection discloses any such defects occurring due to defective material and workmanship in normal usage.

5. The consequential charge for sending back the products to our Maintenance Department or his authorized maintenance stations should be afforded by the consumer.
6. Following states/provinces do not allow limitations on how long an implied warranty lasts, or the exclusion or limitation of special, incidental or consequential damages, so these limitations and exclusions may not apply to you.
 - (1) This warranty is to the original consumer purchaser only, and excludes product damage due to installation error, product abuse, or product misuse, whether performed by a contractor, service company, or the member of consumer.
 - (2) We are not responsible for labor charges, removal charges, installation, or other incidental or consequential costs. (When quality is disputed, China standard is adopted to check and accept.)
 - (3) The problems caused by water pressure shortage, impurity superabundance in water,

Improper usage and cleaning are not covered by this warranty. Unlisted expenses of repair and fittings, as well as installation expenses will void the warranty.

- (4) The changes caused by natural abrasion and water drip. Natural wastage by regular maintenance——e.g. to replace the washer, sealant regularly.
- (5) The liability of applicability to the local byelaw. (Owing to different byelaws in different districts, the franchised agent, contractor and consumer should decide to obey the local byelaw for installation or choose special products to instead of.
7. If you need warranty services, please contact local franchisor of our Plumbing Industrial Co. Ltd., describe product type, meanwhile attach 'Valid Purchase Product Invoice'. 'Valid Purchase Invoice' refers to an invoice under the unified supervision and manufacture of financial and tax departments and it is a valid proof for selling the product. Generally the invoice defined the information clearly: stamp of the seller, selling time, item description, specification, item number, bar code number and unit price and so forth.
8. During warranty, We provides services according to the blemish degree or the seriousness of the quality problem. After warranty expires, We or his authorized maintenance stations will provide compensated maintenance services.
9. During warranty, if a defect is found in normal residential use, the consumer should adopt following measures:
 - (1) Send the product to our Maintenance Department or his authorized maintenance stations or the franchisers to desire services, besides with 'Valid Purchase Invoice', the invoice is unalterable otherwise blank out.
 - (2) Call our local after-service telephone number to acquire right service information.
10. All replaced spare parts, fittings and accessories after maintenance belong to us. We are not responsible for removal or installation costs from other equipments, these expenses will avoid the free warranty.
11. As for our warranty obligations, no matter the warranty clauses or other elucidation may implicit or represent implied, all be considered to be included or limited in the warranty range and period listed by warranty clauses.
12. During warranty, it is the only remedy measure to the consumer's loss caused by defect for the consumer according to warranty clauses. In other words, us are irresponsible to other direct or indirect loss of the consumer.
13. China's compulsive provision in related laws is the same with these warranty clauses.
14. Any franchiser and his agent or maintenance station authorized by us has no right to admit or take on obligations beyond the category of the warranty clauses on behalf of us, and to abandon any right under the warranty clauses either.
15. All information is written in accordance with the latest product information, product characteristics, structure, type of packaging or products available subject to change without notice. (The Company reserves the right to interpret).